



MIRILLA PN10/16/150# BRIDAS

SIGHT PN10/16/150# FLANGED

Fig. 6005

Características / Features

Diseño / Design	Tapas atornilladas / Bolted caps
Rating	PN10/16/150#
Distancia entre caras / Face to face	Según tabla de dimensiones / According to dimension table
Extremos / Ends	Bridas DIN.ANSI / DIN.ANSI Flanged

Materiales / Materials

N°	Descripción / Part name	Material
1	Cuerpo / Body	A216 WCB / A351 CF8M
2	Junta / Gasket	PTFE
3	Visor / Glass	Vidrio templado / Tempered glass

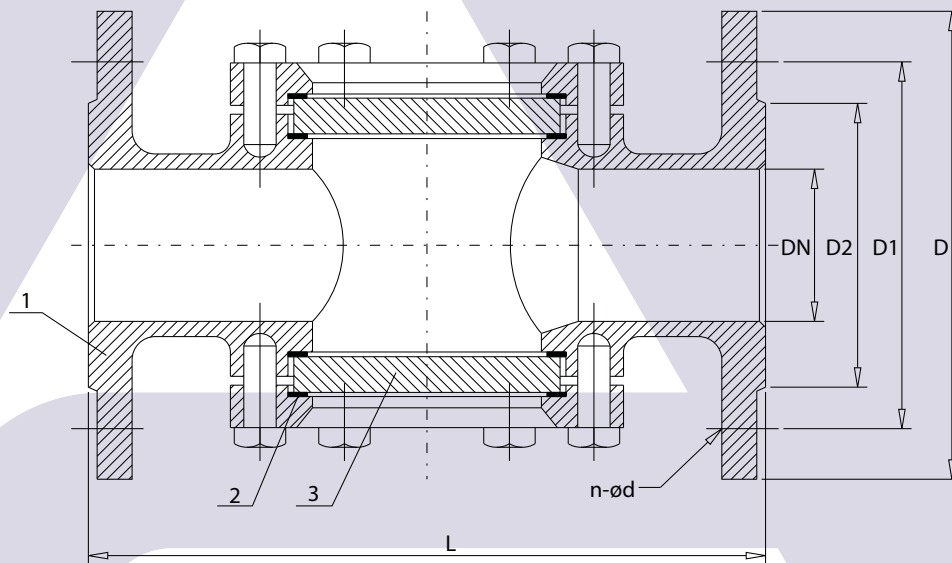

Dimensiones / Main dimensions

Tamaño / Size		L	D	D1	D2	n-ød	Peso Kg
DN	NPS						
15	1/2"	130	95	65	45	4-14	2,35
20	3/4"	150	105	75	58	4-14	2,9
25	1"	160	115	85	68	4-14	3,5
32	1-1/4"	180	140	100	78	4-18	5,6
40	1-1/2"	200	150	110	88	4-18	8,3
50	2"	230	165	125	102	4-18	9,6
65	2-1/2"	290	185	145	122	4-18	13,5
80	3"	310	200	160	138	8-18	17
100	4"	350	220	180	158	8-18	24

PN10/16